

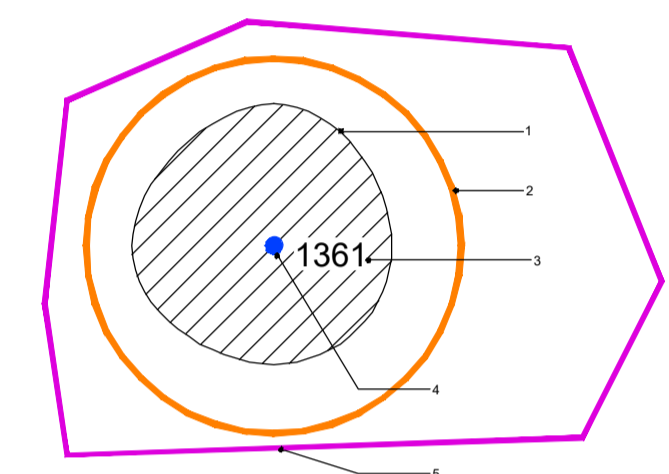

LEGEND

- **CATEGORY A (A1, A2, A3)**
Those in high quality and value: in such condition as to be able to make a substantial contribution (a minimum of 40 years)
- **CATEGORY B (B1, B2, B3)**
Those of moderate quality and value: those in such a condition in order to make a significant contribution (a minimum of 20 years)
- **CATEGORY C (C1, C2, C3)**
Those of low quality and value: currently in an inadequate condition to remain until new planting could be established (a minimum of 10 years) or young trees with a stem diameter below 150mm
- **CATEGORY U**
Those in such a condition that any existing value would be lost within 10 years and which should, in the current context, to be removed for reason of sound arboricultural management



- ① Existing tree canopy in 4 directions: north, south, east west
- ② Root protection area
- ③ Tree tag number
- ④ Tree category based on BS:5837 2012 criteria
- ⑤ Tree protection fencing

1. This drawing is intended to show landscape architectural proposals only. Please refer to Architects and Engineers drawings for relevant details of buildings, structures, roads, parking, etc.
 2. The copyright of this drawing is vested with Murray & Associates. This drawing may not be copied or reproduced without written consent.
 3. All materials referred to on this drawing, including plant species, are indicative and subject to change following detailed site investigation. Significant changes, if any are required, will be referred to the relevant authority for agreement.
 4. This drawing is not suitable for use for construction purposes.
 5. Discrepancies to be referred to Murray & Associates for clarification.

murray & associates
landscape architecture

16 The Seaport Building, mail@murray-associates.com
 44-45 Clontarf Road, www.murray-associates.com
 Dublin 3, D03 RFE2, +353 (0)1 604 0000

REV/DATE	REVISION	DRAWN	CHECKED
A	05/07/22	Issue	IV MB
0	17/06/22	Planning	IV MB

CLIENT
Tetrarch Residential Ltd

PROJECT TITLE
Stradbroke Road SHD

SHEET TITLE
Tree Inventory Plan

SHEET NO.	SHEET SIZE
1873_TS_P_01	A1
SCALE	REVISION
1:200	A
STAGE	DATE
Planning	05/07/22